



CONTROL OF VOLTAGE SOURCE INVERTER USING SVPWM FOR THREE PHASE INDUCTION MOTOR DRIVE APPLICATIONS

¹J.GOPI and ²S.RAJASEKAR B.E.,
(¹Assistant prof.) (²PG Student)

Rajasekar790@gmail.com, powerelectronicstrichy@gmail.com

ABSTRACT

The Pulse Width Modulation technique used in variable speed drives are increasingly applied in many new industrial applications that require superior performance. Recently, developments in power electronics and semiconductor technology have lead improvements in power electronic systems. Hence, different circuit configurations namely multilevel inverters have become popular and considerable interest by researcher are given on them. Variable voltage and frequency supply to a.c drives is invariably obtained from a three-phase voltage source inverter. A number of Pulse width modulation (PWM) schemes are used to obtain variable voltage and frequency supply. The most widely used PWM schemes for three-phase voltage source inverters are carrier-based sinusoidal PWM and space vector PWM (SVPWM). There is an increasing trend of using space vector PWM (SVPWM) because of their easier digital realization and better dc bus utilization. This project focuses on step by step development SVPWM implemented on an Induction motor. The model of a three-phase a voltage source inverter is discussed based on space vector theory.

INTRODUCTION

In space vector PWM concept has the hexagon consists of six sectors and eight states (including six active states and two zero states). SVPWM hexagon has rotating space vector V_{ref} with variable angle (varies from 0-360deg). V_{ref} has also two adjacent vectors with two switching times T_a , T_b . the switching pulses is generated depends upon the trigger signal and sector position. Trigger is produced by comparison of switching times with carrier rectangle frequency. T_a , T_b , T_o are calculated by the use of sector numbers which calculated from sector determination, V_{ref} , $T_z(1/\text{switching Frequency}=1/f_z)$. Depending upon the trigger signal switching pulses for VSI is generated.

In sinusoidal PWM switching pulse is generated by comparing the three phase wave with triangular wave. when the three phase wave is lower than the triangular wave amplitude there will be high signal which is used for turn on the switches of VSI, each and every one phase is comparing with triangular wave separately for upper switches of the inverter and this switching pulses are converted to opposite which is used for lower switches. In this project carrier based sinusoidal pulse width

modulation technique is compared with space vector pulse technique and the benefits of going for space vector PWM rather than others is also briefly explained. Finally we are going analysis total harmonic distortion of both SVPWM and SPWM.

An adjustable speed drive (ASD) is a device used to provide continuous range process speed control. An ASD is capable of adjusting both speed and torque from an induction or synchronous motor. An electric ASD is an electrical system used to control motor speed. ASDs may be referred to by a variety of names, such as variable speed drives, adjustable frequency drives or variable frequency inverters. The latter two terms will only be used to refer to certain AC systems, as is often the practice, although some DC drives are also based on the principle of adjustable frequency.[6]

Adjustable speed drives are the most efficient (98% at full load) types of drives. They are used to control the speeds of both AC and DC motors. They include variable frequency/voltage AC motor controllers for squirrel-cage motors, DC motor controllers for DC motors, eddy current clutches for AC motors (less efficient), wound-rotor motor controllers for wound-rotor AC motors (less efficient) and cycloconverters (less efficient). Pulse Width

Modulation variable speed drives are increasingly applied in many new industrial applications that require superior performance. Recently, developments in power electronics and semiconductor technology have led to improvements in power electronic systems. Hence, different circuit configurations namely multilevel inverters have become popular and considerable interest by researchers is given on them. Variable voltage and frequency supply to a A.C drives is invariably obtained from a three-phase voltage source inverter. A number of Pulse width modulation (PWM) schemes are used to obtain variable voltage and frequency supply. The most widely used PWM schemes for three-phase voltage source inverters are carrier-based sinusoidal PWM and space vector PWM (SVPWM). There is an increasing trend of using space vector PWM (SVPWM) because of their easier digital realization and better dc bus utilization.

VOLTAGE SOURCE INVERTER

The function of the VSI is to change the fixed dc input voltage to asymmetric ac output voltage of desired magnitude and frequency. A variable voltage output can be obtained by varying the input dc voltage and maintaining the gain of the inverter at constant level. The inverter gain may be defined as the ratio of the ac output voltage to dc input voltage. A variable output voltage can be obtained by varying the gain of inverter is usually done by pulse width modulation technique (PWM). voltage source inverter input voltage is taken from diode bridge rectifier by dc capacitor link likewise for current source inverter input current is taken from rectifier by inductor link. CSI are robust in operation and reliable due to insensitivity to short circuit and noisy environment. VSI is widely used than CSI due to its higher frequency range and also it is less expensive than CSI.

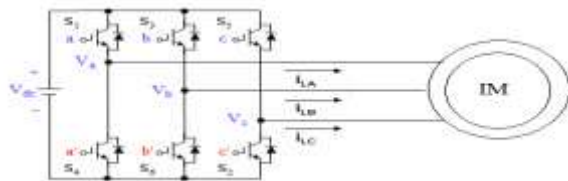

Voltage Vectors	Switching Vectors			Line to neutral voltage			Line to line voltage		
	a	b	c	V_{an}	V_{bn}	V_{cn}	V_{ab}	V_{bc}	V_{ca}
V_0	0	0	0	0	0	0	0	0	0
V_1	1	0	0	2/3	-1/3	-1/3	1	0	-1
V_2	1	1	0	1/3	1/3	-2/3	0	1	-1
V_3	0	1	0	-1/3	2/3	-1/3	-1	1	0
V_4	0	1	1	-2/3	1/3	1/3	-1	0	1
V_5	0	0	1	-1/3	-1/3	2/3	0	-1	1
V_6	1	0	1	1/3	-2/3	1/3	1	-1	0
V_7	1	1	1	0	0	0	0	0	0

(Note that the respective voltage should be multiplied by V_{dc})

Table 2.1 VOLTAGE VECTORS OF VSI

As in single-phase VSI, the switches of any leg of the inverter (S1 and S4, S3 and S6, or S5 and S2) cannot be switched simultaneously because this would result in a short circuit across the dc link voltage supply, similarly in order to avoid undefined states in the VSI and thus undefined ac output line voltages, the switches of any leg of the inverter cannot be switched off simultaneously as this will result in voltages that will depend upon the respective line current polarity. Of the eight valid states, two of them (7th and 0th states) produce zero ac line voltages. In this case, the ac line currents freewheel through either the upper or lower components. The remaining states (1th to 6th state in table) produce non-zero ac output voltages .[5]

In order to generate a given voltage waveform, the inverter moves from one state to another .Thus the resulting ac output line voltages consist of discrete values of voltages that are $V_{dc}, 0, -V_{dc}$ for the topology shown in figure.(2.1.2) The selection of the states in order to generate the given waveform is done by the modulating technique that should ensure the use of only the valid states. The two types of control signals can be applied to the transistors they are 180degree conduction and 120 degree conduction.

The 180 degree conduction has better utilization of the switches. Parallel to power switches, reverse recovery diodes are placed conducting the current depending on the switching states and current sign. These diodes are required, since switching off an inductive load current generates high voltage peaks probably destroying the power switch. The advantage of using PWM are we can get output voltage control without using any additional control and lower order harmonics can be eliminated or minimized by this technique. Higher order harmonics can easily be removed by using filters.

In the voltage source inverter conversion of dc power to three-phase ac power is performed in the switched mode. This mode consists of power semiconductor switches are in controlled on-off fashion. The actual power flow in each line output of inverter is controlled by the duty cycle of the respective switches. To obtain a suitable duty cycle for each switches technique pulse width modulation is used. Many different modulation methods were proposed and development of it is still in progress.

The development of modulation methods may improve converter parameters. In the carrier based PWM methods the zero sequence signals (ZSS) are used to extend the linear operation range. All PWM methods have specific features. However, there is not just one PWM method which satisfies all requirements in the whole operating

region. The space vector pulse width modulation is considered to be good because it has full control voltage including overmodulation and six-step mode, achieved by various algorithms and there is a reduction of switching loss, harmonics. It is necessary to control the output voltage of inverters:1. To cope with the variation of dc input voltage.2. To satisfy the constant volts and frequency control requirement. In PWM inverters, forced commutation is essential. The three PWM techniques listed above differ from each other in their respective output voltages. Thus, choice of a particular PWM technique depends upon the permissible harmonic content in the inverter output voltage.

In industrial applications, PWM inverter is supplied from a diode bridge rectifier and an output filter (LC). The output voltage wave forms of ideal inverters should be sinusoidal. However, the waveforms of practical inverters are non-sinusoidal and contain harmonics. For low-and medium –power applications, square- wave or quasi-square-wave voltages are applicable and for high-power applications, low distorted sinusoidal waveforms are required. The output is directly fed from the inverter to the drive and bi-directional power flow is an important feature for the motor drives as it allows regenerative braking.

The input to the VSI may be a battery cell, fuel cell, solar cell, or other dc source. The devices used for the inverters are (bipolar junction transistor [BJT], insulated-gate bipolar transistors [IGBT], metal oxide semiconductor-controlled thyristors [MCTs], static induction transistors, [SITs] and gate-turn-off thyristors [GTOs]).

SINUSOIDAL PWM

It is very popular for industrial converters. In this method a triangular wave is compared to a sinusoidal wave of the desired frequency and the relative levels of the two waves is used to control the switching of devices in each phase leg of the inverter. [7]

m=modulation index, The modulation index m is defined.

$$m = V_p / V_T$$

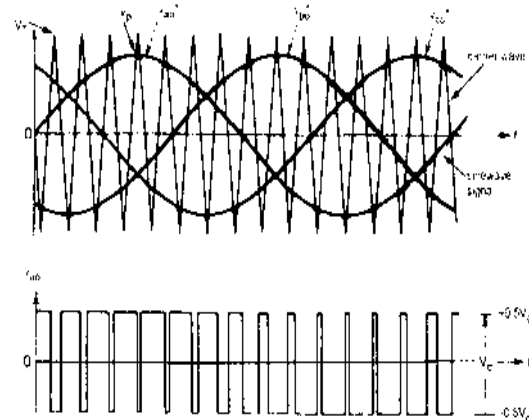

SPACE VECTOR PWM

The space vector PWM is an advanced, computation intensive PWM method and is possibly good among all the PWM techniques for variable frequency load applications. There is an increase in trend of using SVPWM due its digitalization and better dc bus utilization. Generally SVPWM technique has high output voltage and low current harmonics of inverter. When we increase the carrier frequency of the PWM it will results in lower harmonics. In space vector PWM concept has the hexagon consists of six sectors and eight states (including six active states and two zero states). [5]

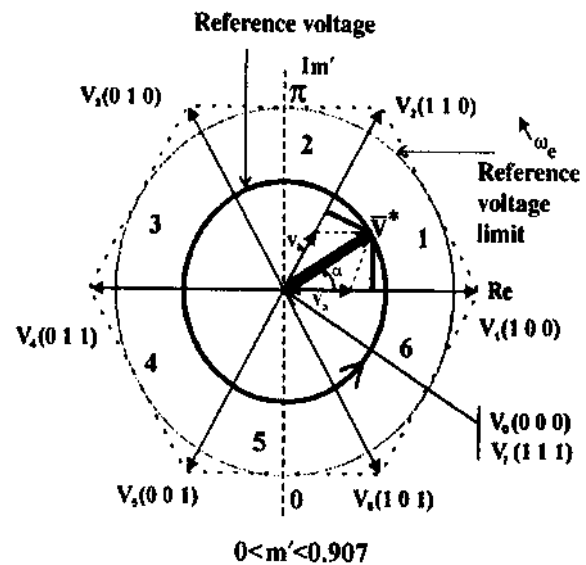

SVPWM hexagon has rotating space vector V_{ref} with variable angle (varies from 0-360deg). V_{ref} has also two adjacent vectors V_a, V_b with two switching times T_a, T_b . the switching pulses is generated depends upon the trigger signal and sector position. Trigger is produced by comparison of switching times with carrier rectangle frequency. T_a, T_b, T_o are calculated by the use of sector numbers Which calculated from sector determination,

V_{ref}, T_z (1/switching Frequency=1/ f_z). Depending upon the trigger signal switching pulses for VSI is generated.

MODELING OF SVPWM

- Determination of V_{mag} , alpha

$$V_{mag} = ((2 * V_{dc} * \text{modulation index}) / \pi)$$

The alpha is generated by using the function $\text{rem}(\omega t * 2\pi)$ which is used to generate the angle of the V_{mag} in the range (0-360deg) $\omega t = 2 * \pi * f * t$

- Determination of sector depending upon the alpha value sector number is calculated. This is explain in the simulink model.[5]
- Determination of switching time T_a, T_b, T_0

$$V^* \sin(\pi/3 - \alpha) = V_a \sin(\pi/3) \tag{1}$$

$$V^* \sin(\alpha) = V_b \sin(\pi/3) \tag{2}$$

$$V_a = 2/3^{1/2} V^* \sin(\pi/3 - \alpha) \tag{3}$$

$$V_b = 2/3^{1/2} V^* \sin(\alpha) \tag{4}$$

$$V^* = V_a + V_b = V_1(t_a/T_c) + V_2(t_b/T_c) + (V_0 \text{ or } V_7)(t_0/T_c) \tag{5}$$

$$V^* T_c = V_1 t_a + V_2 t_b + (V_0 \text{ or } V_7) t_0 \tag{6}$$

$$t_a = V_a / V_1 * T_c \tag{7}$$

$$t_b = V_b / V_1 * T_c \tag{8}$$

$$t_0 = T_c - (t_a + t_b) \tag{9}$$

- Generation of trigger pulse

$T_0/2$ value is compared with the positive slope of carrier wave when the (V_c (Carrier amplitude) $> T_0/2$), it will give high signal otherwise remains zero. Then the value of ($T_0/2 + T_a$) is compared with the positive slope of carrier wave when ($V_c > (T_0/2 + T_a)$), it will give high signal otherwise remains zero. Then the value of ($T_0/2 + T_a + T_b$) is compared with the positive slope of carrier wave when ($V_c > (T_0/2 + T_a + T_b)$), it will give high signal

otherwise remains zero. Then the value of ($T_0/2 + T_a + T_b$) is compared with the negative slope of carrier wave when ($V_c > (T_0/2 + T_a + T_b)$), it will give high signal otherwise remains zero. After that the value of ($T_0/2$) is compared with the negative slope of carrier wave when ($V_c < (T_0/2)$), it will give high signal otherwise remains zero. Then the value of ($T_0/2 + T_a$) is compared with the negative slope of carrier wave when ($V_c < (T_0/2 + T_a)$), it will give high signal otherwise remains zero. Then the value of ($T_0/2 + T_a + T_b$) is compared with the negative slope of carrier wave when ($V_c < (T_0/2 + T_a + T_b)$), it will give high signal otherwise remains zero. All signals from each comparison will get added and get the trigger signal. [3]

- Generation of switching pulses.

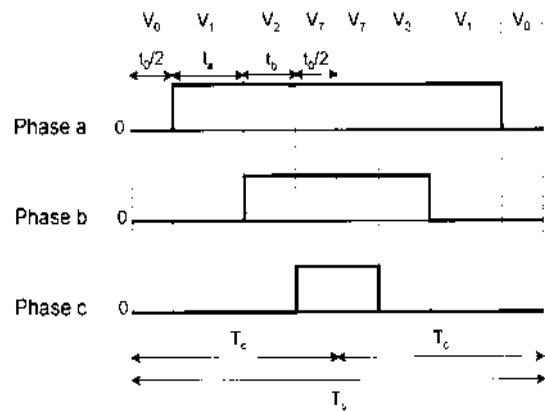

Simulink model of SPWM/Main model

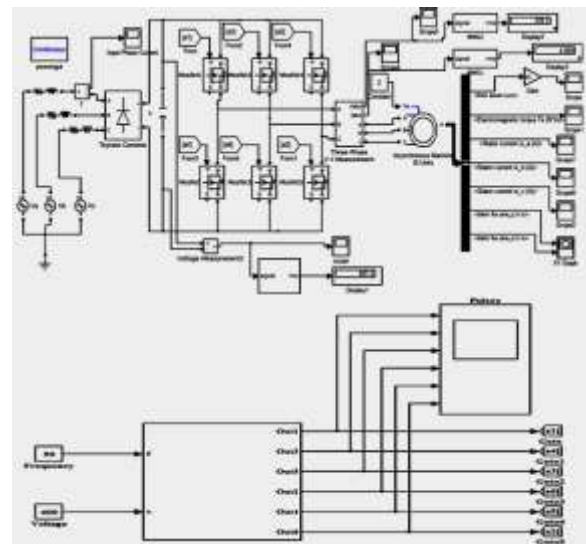

Simulink model of SVPWM/ Main model

MODULATION INDEX	SPACE VECTOR PULSE WIDTH MODULATION		
	CURRENT T.H.D	R.M.S OUTPUT PHASE VOLTAGE	R.M.S OUTPUT PHASE CURRENT
0.5	24.44	356.4	3.019
0.6	24.36	356.8	3.23
0.7	24.34	356.1	3.642
0.8	24.16	358.6	4.391
0.9	24.02	359.5	5.135
1	23.92	360.6	5.986

MODULATION INDEX	SINUSOIDAL PULSE WIDTH MODULATION		
	CURRENT T.H.D	R.M.S OUTPUT PHASE VOLTAGE	R.M.S OUTPUT PHASE CURRENT
0.5	36.67	338.7	2.43
0.6	36.51	339.2	2.86
0.7	36.43	339.8	3.178
0.8	36.29	340.3	3.798
0.9	36.14	340.4	4.293
1	36.02	340.9	4.468

Simulink model of SVPWM Trigger signal generation

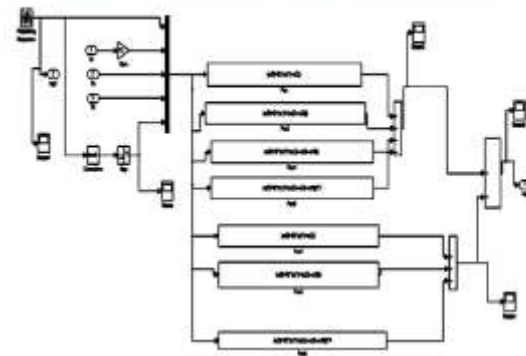

STATOR CURRENT

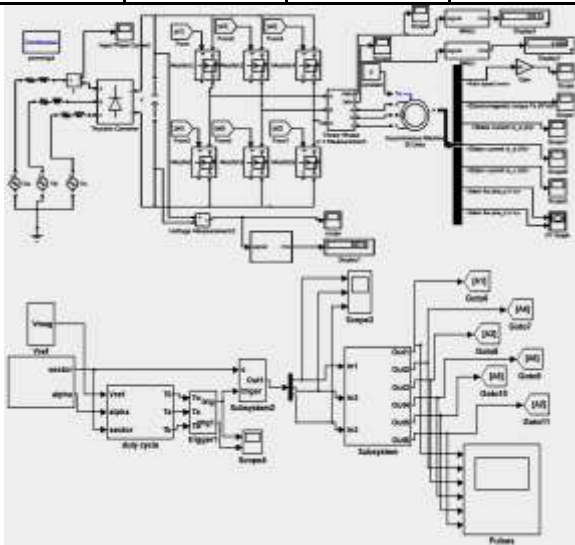
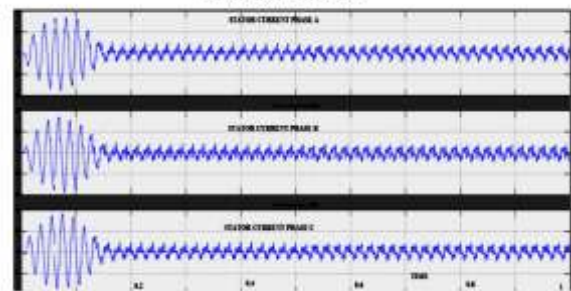

REFERENCES

1. J. Holtz, "Pulse width modulation for electronic power conversion," *Proc. IEEE*, vol. 82, pp. 1194–1214, Aug. 1994.
2. O. Ogasawara, H. Akagi, and A. Nabel, "A novel PWM scheme of voltage source inverters based on space vector theory," in *Proc. EPE European Conf. Power Electronics and Applications*, 1989, pp. 1197–1202.
- 3) M. Depenbrock, "Pulsewidth control of a 3-phase inverter with nonsinusoidal phase voltages," in *Proc. IEEEAS Int. Semiconductor Power Conversion Conf., Orlando, FL*, 1975, pp. 389–398.
- 4) J. A. Houldsworth and D. A. Grant, "The use of harmonic distortion to increase the output voltage of a three-phase PWM inverter," *IEEE Trans. Ind. Applicat.*, vol. 20, pp. 1224– 1228, Sept./Oct. 1984.
- 5) *Modern Power Electronics and AC Drives*, by Bimal K. Bose. Prentice Hall Publishers, 2001

6) *Power Electronics* by Dr. P.S. Bimbhra. Khanna Publishers, New Delhi, 2003. 3rd Edition.

7) *A Power Electronics Handbook* by M.H. Rashid. Academic Press 2001.